



SAJ



8000B Series Enhanced Inverter
User Manual



Version code: 8000B-E201208-1MB

TABLE OF CONTENTS

Notes for Safe Operation	01
Notes for Other Important Operations	06
Chapter 1 Select the Right Type	08
1.1 Description of Model.....	08
1.2 Description of Nameplate.....	08
1.3 8000B Series Inverter Table.....	09
1.4 Specifications of 8000B Series Inverter.....	10
1.5 Outline Drawing and Dimensions.....	12
1.6 Selection Instruction Table of Brake Resistor and Brake Unit.....	17
Chapter 2 Mechanical and Electric Installation	18
2.1 Mechanical Installation.....	18
2.2 Electric Installation.....	19
Chapter 3 Wiring	23
3.1 Standard Wiring Diagram.....	23
3.2 Terminal Descriptions of Main Circuit and Control Circuit.....	27
Chapter 4 Operation	32
4.1 Keypad Description.....	32
4.2 Operation Process.....	33
Chapter 5 Function Code Table	36
Chapter 6 Trouble Shooting	64
6.1 Fault and Trouble Shooting.....	64
6.2 Common Faults and Solutions.....	68
Chapter 7 Data Address Table of Function Code	69

PRECAUTION

Never modify the products. Failure to observe this warning can result in electrical shock or personal injury. SAJ is not responsible for any modification of the frequency products made by the user, since that will void your guarantee.

Notes for Safe Operation

Read this instruction manual thoroughly before installation, operation, maintenance or inspection of the frequency inverters. In this manual, safe operation are classified as “WARNING” or “CAUTION”.

WARNING

Indicate a potentially dangerous situation which, if not avoided, could result in death or serious injury to personnel.

CAUTION

Indicate a potentially dangerous situation which, if not avoided, could result in minor or moderate injury and damage to equipment. It may also be used for warning against unsafe practices.

Even items described as ( CAUTION) may result in a vital accident in some situations. Please follow these important notes:

NOTE

These are steps to be taken to ensure proper operation.

Before Installation

WARNING

Do not install or operate any frequency inverter that is damaged or has missing parts.

Choose the motor of insulation class B or above. Otherwise it may cause an electrical shock.

Installation

 WARNING

Install the frequency inverter on nonflammable material like metal. Otherwise it may cause a fire.

 WARNING

Make sure that the mounting environment away from metal dust. Otherwise it may cause damage to the frequency inverter.

 CAUTION

When mount over two inverters in the same cabinet or enclosure, install a fan or other cooling device to keep the temperature inside below 50°C .

Do not let the conductor head or screws fall into the inside of the inverter. Otherwise it may cause damage to the inverter.

Wiring

 WARNING

Ensure only qualified personnel to operate. Otherwise it can cause an electrical shock.

Make sure the inverter is isolated from power supply by the circuit breaker. Otherwise it may cause a fire.

Verify that the power supply is turned OFF before start wiring. Otherwise it may cause an electrical shock or fire.

Make sure that the ground terminal is grounded correctly. Otherwise it may cause an electrical shock.

 CAUTION

Never connect the AC power supply to output terminals U, V and W. Otherwise the inverter will be damaged and the guarantee is invalid.

Make sure that wiring conform to EMC requirements and local power safe standard. Make sure to use right wire according to this instruction manual. Otherwise it may cause an accident.

Braking resistor or braking unit cannot be directly connected to DC bus terminals (P+) and (N-). Otherwise it may cause a fire.

Before Turn on the AC Power Supply WARNING

Make sure that the voltage of inverter conforms to the local power supply voltage. Verify that the wiring of input and output is correct and there is no short-circuit in peripheral circuit. Tighten the terminal screws. Otherwise these may cause damage to the inverter.

Turn on the input AC power only after the front cover is put correctly. Otherwise it may cause an electrical shock.

 CAUTION

Never perform a hi-pot or withstand voltage test of the inverter. Otherwise it may cause damage to the inverter.

Make sure that the optional parts are connected correctly. Otherwise it may cause damage to the inverter.

When the Power is On **WARNING**

Do not open or remove the front cover when operation. Otherwise it may cause an electrical shock.

Never touch the inverter and optional parts by wet hands. Never touch the connection terminals. Otherwise it may cause an electrical shock.

When the power is on, the inverter will automatically check the power supply circuit. Do not touch U, V, W terminals and motor connection terminals. Otherwise it may cause an electrical shock.

 **CAUTION**

It is dangerous for the personnel to approach the motor and load during rotation of the motor. Do not change the factory parameters or settings unnecessarily. Otherwise it may cause a damage or injury.

Operation **WARNING**

When select the function of restart, do not approach the mechanical load. Otherwise it may cause an injury if it restarts suddenly.

Do not touch the heat sink or discharging resistor. Otherwise it may cause harmful burns to the body.

Never change or check signals if not a professional or qualified personnel. Otherwise it may cause damage and injury.

 **CAUTION**

Make sure nothing fall into the mechanical load or inverter. Otherwise it may cause damage.

Start or stop inverter by corresponding buttons only. Otherwise it may cause damage.

Maintenance **WARNING**

After the main circuit power supply is OFF, make sure the charge LED is OFF when maintain or inspect. Never maintain or inspect the inverter and mechanical load when the power supply is still ON. Otherwise it may cause damage and injury.

Only qualified or authorized professional personnel can maintain, replace and inspect the inverter. Otherwise it may cause damage and injury.

Notes for Other Important Operations



1. Check Insulation of the Motor

Check insulation of the motor and wire when the motor is used again after long time idle or for the first time. Disconnect the wire between the motor and the inverter before check insulation. Make sure the insulation resistor is not below 5MΩ.

2. Thermal Overload Protection of the Motor

When the rated capacity of inverter is larger than that of the motor, install thermal overload relay for the motor or regulate the motor protection parameters of the inverter.

3. Consider the Bearing Capability of the Load

The inverter can provide output frequency from 0 Hz to 600 Hz. If the motor needs to work at over 50 Hz, user should consider the bearing capability of the load.

4. Avoid Mechanical Resonance Frequency

Regulate the skip frequency parameter of the inverter to avoid mechanical resonance frequency of the load.

5. Prohibition of Installation of Phase Advancing Capacitor

If a phase advancing capacitor or surge suppressor is connected in order to improve the power factor, it may become overheated and damaged by inverter high harmonic components. Also, the inverter may malfunction because of over current.

6. Installation of Magnetic Contactor

If a magnetic contactor is installed at the power supply side, do not use it to control the start of the inverter. If necessary, the time span should be one hour or above. Otherwise frequent switching may cause the inverter to malfunction.

If a magnetic contactor is installed between the output terminals and motor (output side of the inverter), make sure there is no output of inverter before switch on and off. Otherwise it may cause damage to the inverter.

7. Allowable Voltage Range and Power Supply Phase

Make sure the inverter works under allowable voltage range. If necessary, use boosting transformer or step-down transformer to change the voltage of power supply. Never change the 3-phase of inverter into 2-phase. Otherwise it will cause damage to the inverter.

8. Thunder Stroke Protection

Even there is protection device to protect the inverter from induction thunder stroke, it's necessary for users in frequent thunder stroke area to install other protective device.

9. Altitude and Degradation Use

At an altitude of 1000m or above, it could be better that use the motor with lower rated capacity. Otherwise the inverter may become overheated because of rare air. For example, in order to control the motor of 4kW rated capacity, it could be better to use 5.5kW inverter.

10. Dispose of Scrap Inverter

The scrap capacitor of main circuit and PCB (printed-circuit board) may explode when it is burned. In order to protect the environment, do not burn waste plastic parts and scrap capacitor.

11. Choose the Right Matching Inverter for the Motor

The standard matching motor is 4-pole inductive motor. If not, choose the right matching inverter according to the rated current of the motor.

According to the actual working situation of the motor, the factory setting of motor standard parameter can be revised. Otherwise it may cause low efficiency to the unit.

Chapter 1 Select the Right Type

1.1 Description of Model

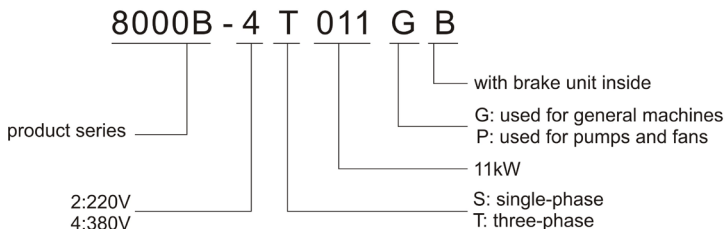

1.2 Description of Nameplate

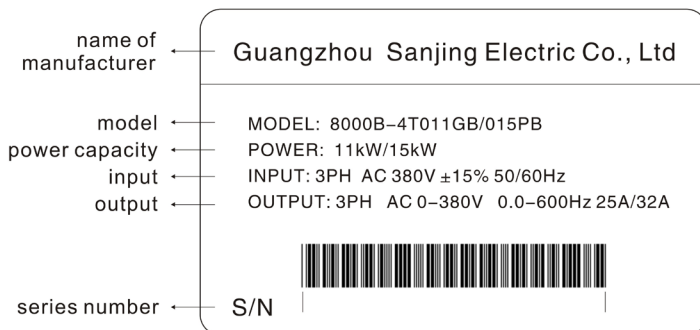

1.3 8000B Series Inverter Table

Inverter Model G/P	Power capacity kW	Rated Input Current A	Rated Output Current A	Motor Capacity kW G/P
Single-phase 220V±15%				
8000B-2SR75GB	0.75	8.2	4.5	0.75
8000B-2S1R5GB	1.5	14.2	7	1.5
8000B-2S2R2GB	2.2	23	10	2.2
Three-phase 380V±15%				
8000B-4TR75GB	0.75	3.4	2.5	0.75
8000B-4T1R5GB	1.5	5	3.7	1.5
8000B-4T2R2GB	2.2	5.8	5.0	2.2
8000B-4T004GB/4T5R5PB	4/5.5	10/15	9/13	4/5.5
8000B-4T5R5GB/4T7R5PB	5.5/7.5	15/20	13/17	5.5/7.5
8000B-4T7R5GB	7.5	20	17	7.5
8000B-4T011GB/4T015PB	11/15	26/35	25/32	11/15
8000B-4T015GB/4T18R5PB	15/18.5	35/38	32/37	15/18.5
8000B-4T18R5GB	18.5	38	37	18.5
8000B-4T022G/4T030P	22/30	46/62	45/60	22/30
8000B-4T030G/4T037P	30/37	62/76	60/75	30/37
8000B-4T037G	37	76	75	37
8000B-4T045G/4T055P	45/55	90/105	90/110	45/55
8000B-4T055G/4T075P	55/75	105/140	110/150	55/75
8000B-4T075G/4T093P	75/93	140/160	150/176	75/93
8000B-4T093G/4T110P	93/110	160/210	176/210	93/110
8000B-4T110G	110	210	210	110
8000B-4T132G/4T160P	132/160	240/290	250/300	132/160
8000B-4T160G/4T185P	160/185	290/330	300/340	160/185
8000B-4T185G	185	330	340	185
8000B-4T200G/4T220P	200/220	370/410	380/415	200/220
8000B-4T220G/4T250P	220/250	410/460	415/470	220/250
8000B-4T250G/4T280P	250/280	460/500	470/520	250/280
8000B-4T280G/4T315P	280/315	500/580	520/600	280/315
8000B-4T315G	315	580	600	315
8000B-4T350G	350	620	640	350
8000B-4T400G	400	670	690	400

1.4 Specifications of 8000B Series Inverter

Characteristics of Controlling	Control Mode	Sensorless vector control	V/F control
	Start Torque	0.5Hz 150%	0.5Hz 100%
	Rotation Speed Ratio	1:200	1:100
	Precision of Speed Regulation	±0.5%	±1.0%
	Overload Capability	Model G:150% above the rated current for 60 seconds;180% above the rated current for one second. Model P:120% above the rated current for 60 seconds;150% above the rated current for one second.	
	V/F curve	Three selection type: Linear type, Square type and Multipoint type.	
	DC Brake	DC brake frequency:0.00~max. frequency; brake time:0.1~50.0s; Brake current:0~150% of rated current(model G); 0~100% of rated current:model P); Brake waiting time:0.0~50.0s	
	Jog Operation	Jog frequency range:0.00-max.frequency; Accel./Decel. time of jog operation:0.1~3600s.	
	Accel./Decel. Time	Accel./Decel. time range:0.1~3600s	
	Torque Boosting	Manual setting:0.1~30.0%; Automatic setting:0.0	
I/O Characteristics	Start Frequency	0.50~10Hz	
	Input Voltage	220V/380V ± 15%	
	Input Frequency	50/60Hz, fluctuation range:±5%	

I/O Characteristics	Input Frequency Resolution	Analog setting: max. frequency \times 0.1%; Digital setting: 0.01Hz
	Output Voltage	0~rated input voltage
	Output Frequency Range	0.00~600Hz
	Digital Input Terminals	Six (programmable)
	Analog Input Terminals	AVI: 0~10V; ACI: 0~10V or 0/4~20mA
	Relay Output	1 relay output
	Open Collector Output	Provide 1 channel programmable
	Analog Output	0.75~2.2kW: FM: 0~10V; AM: 0/4~20mA 4~400kW: FM: 0~10V; AM: 0~10V / 0/4-20mA
Basic Functions	Frequency Setting Channels	Three channels: setting by keyboard, setting by control terminals, setting by serial communication interface. These channels can be switched.
	Frequency Setting Source	8 methods including panel knob setting, UP/DOWN key setting and PID setting, etc.
	Simple PLC Function	16 steps speed control can be carried out by simple PLC function inside and terminals.
	PID Function	Close-loop controlling system can be carried out by PID inside.
	Swing Frequency Function	Suitable for textile and chemical fiber machine by controlling the triangular frequency.
	AVR Function	Automatically keep the output voltage constant when power supply is not stable.

Other Functions	LED Display	16 parameters can be displayed including running frequency, DC bus voltage, output voltage, output current, etc.
	Communication Function	RS485 with standard MODBUS protocol.
	Password Setting	Four-digit password can be set and become effective after 1 minute.
	Parameter Lock Function	This function can be used to lock the parameter when running or stop in order to avoid wrong operation.
	Fault Protection Function	Over-current, overvoltage, under-voltage, over temperature, lack of phase, etc.
Application Environment	Location	Indoor away from sunlight, dust, corrosive gas, oil fog, water drop, steam.
	Elevation	1000m or less
	Ambient Temperature	-10°C ~+40°C
	Humidity	95% RH or less
	Vibration	< 5.9 m/s ² (0.6G)

1.5 Outline Drawing and Dimensions

1.5.1 Outline Drawing

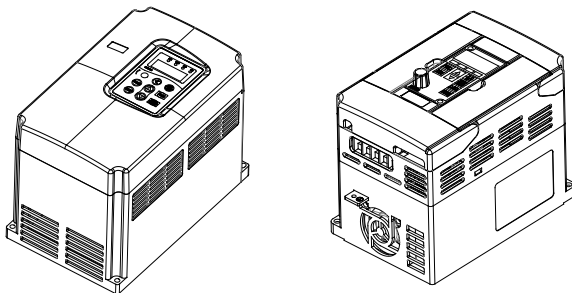

1.5.2 Dimensions

1.5.2.1 Dimensions Drawing

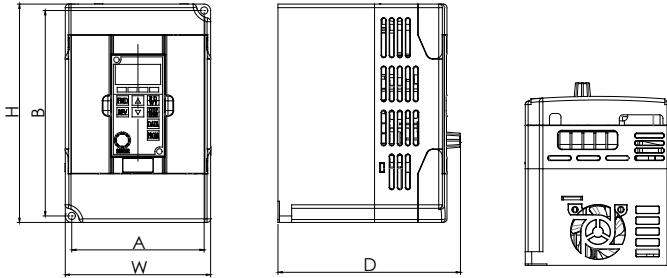

0.75kW~2.2kW (model G)

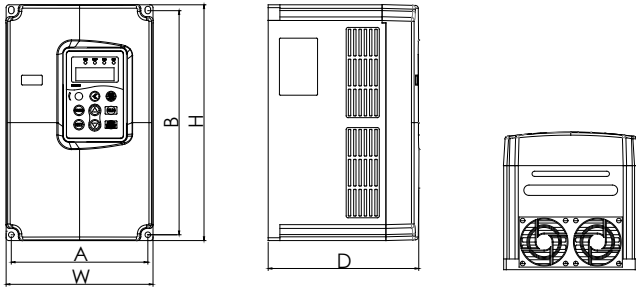

4kW~7.5kW (model G)

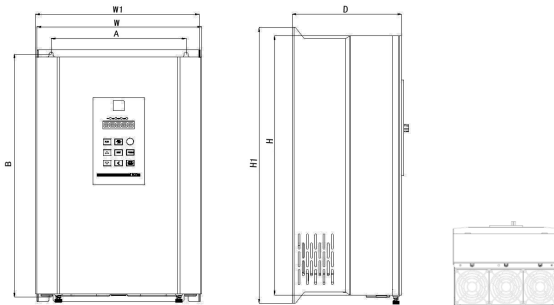

11kW~110kW (model G)

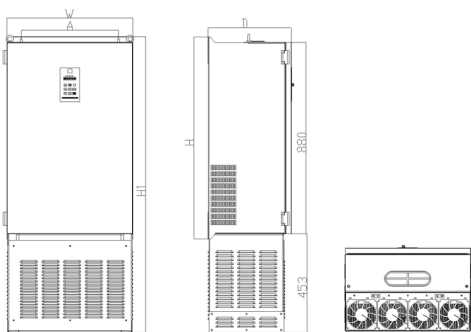

132kW~185kW (model G)

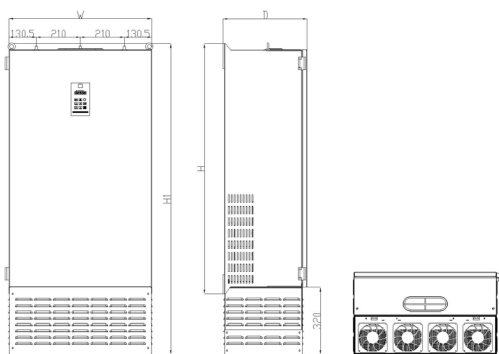

200kW~250kW (model G)

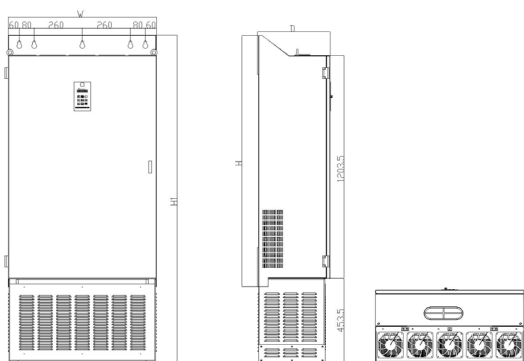

280kW~400kW (model G)

1.5.2.2 Dimensions Table

Inverter Model	Installation Dimensions (mm)		Appearance Dimensions (mm)					Hole Diameter (mm)
	A	B	H	H1	W	W1	D	
8000B-2SR75GB	92	142.7	151.7		101		126.8	ø5
8000B-2S1R5GB								
8000B-2S2R2GB								
8000B-4TR75GB	92	142.7	151.7		101		126.8	ø5
8000B-4T1R5GB								
8000B-4T2R2GB								
8000B-4T004GB/4T5R5PB	144.4	237	249.5		155.5		159.5	ø5.9
8000B-4T5R5GB/4T7R5PB								
8000B-4T7R5GB								
8000B-4T011GB/4T015PB	156.6	378.3	364	396	214	221.7	190.5	ø6
8000B-4T015GB/4T18R5PB								
8000B-4T18R5GB								
8000B-4T022G/4T030P	235	447	424	463	285	289.6	210.3	ø7
8000B-4T030G/4T037P								
8000B-4T037G								
8000B-4T045G/4T055P	260	580	544	595.5	380	390	284.8	ø10
8000B-4T055G/4T075P								
8000B-4T075G/4T093P	343	674	650	701.5	473	485	318	ø10
8000B-4T093G/4T110P								
8000B-4T110G								
8000B-4T132G/4T160P	449	902.5	927	1359	580		384	ø10
8000B-4T160G/4T185P								
8000B-4T185G								
8000B-4T200G/4T220P	420	1162	1131.5	1481.6	680		400.5	ø12
8000B-4T220G/4T250P								
8000B-4T250G/4T280P								
8000B-4T280G/4T315P	520	1300	1355	1765	800		392.5	ø14
8000B-4T315G								
8000B-4T350G								
8000B-4T400G								

1.5.2.3 Dimensions of Extension Keyboard

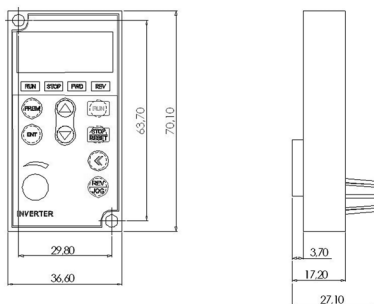

0.75kW~2.2kW (model G)

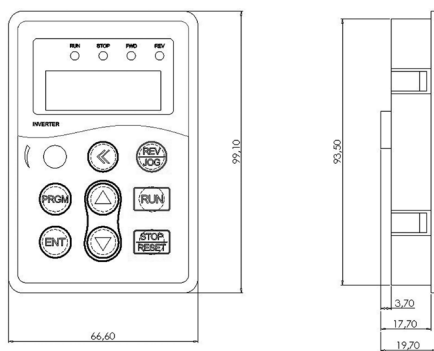

4kW~7.5kW (model G)

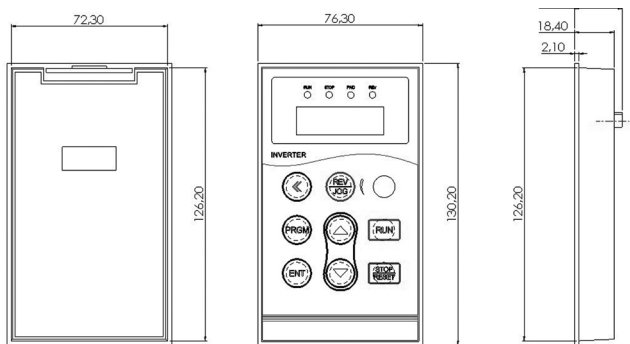

11kW~400kW (model G)

1.6 Selection Instruction Table of Brake Resistor and Brake Unit

Inverter Model	Recommended Power of Brake Resistor	Recommended Resistance Value of Brake Resistor	Brake Unit
8000B-2SR75GB	80W	≥150Ω	Standard Accessory Inside
8000B-2S1R5GB	100W	≥100Ω	
8000B-2S2R2GB	100W	≥70Ω	
8000B-4TR75GB	150W	≥300Ω	
8000B-4T1R5GB	150W	≥220Ω	
8000B-4T2R2GB	250W	≥200Ω	
8000B-4T004GB/4T5R5PB	300W	≥130Ω	
8000B-4T5R5GB/4T7R5PB	400W	≥90Ω	
8000B-4T7R5GB	500W	≥65Ω	
8000B-4T011GB/4T015PB	800W	≥43Ω	
8000B-4T015GB/4T18R5PB	1000W	≥32Ω	
8000B-4T18R5GB	1300W	≥25Ω	
8000B-4T022G/4T030P	1500W	≥22Ω	
8000B-4T030G/4T037P	2500W	≥16Ω	
8000B-4T037G	3.7 kW	≥16.0Ω	
8000B-4T045G/4T055P	4.5 kW	≥16Ω	
8000B-4T055G/4T075P	5.5 kW	≥8Ω	
8000B-4T075G/4T093P	7.5 kW	≥8Ω	
8000B-4T093G/4T110P	4.5 kW×2	≥8Ω×2	
8000B-4T110G	5.5 kW×2	≥8Ω×2	
8000B-4T132G/4T160P	6.5 kW×2	≥8Ω×2	
8000B-4T160G/4T185P	16kW	≥2.5Ω	
8000B-4T185G	20 kW	≥2.5Ω	
8000B-4T200G/4T220P	20 kW	≥2.5Ω	
8000B-4T220G/4T250P	22 kW	≥2.5Ω	
8000B-4T250G/4T280P	12.5 kW×2	≥2.5Ω×2	
8000B-4T280G/4T315P	14kW×2	≥2.5Ω×2	
8000B-4T315G	16kW×2	≥2.5Ω×2	
8000B-4T350G	17kW×2	≥2.5Ω×2	
8000B-4T400G	14 kW×3	≥2.5Ω×3	

Chapter 2 Mechanical and Electric Installation

2.1 Mechanical Installation

2.1.1 Installation Environment

The ambient temperature exerts great influences on the service life of the inverter and is not allowed to exceed the allowable temperature range (-10°C to 40°C).

The inverter should be mounted on the surface of incombustible articles, with sufficient spaces nearby for heat sinking. The inverter is easy to generate large amount of heat during operation. The inverter should be mounted vertically on the base with screws.

The inverter should be mounted in the place without vibration or with vibration of less than 0.6G

The inverter should be mounted in locations away from direct sunlight, high humidity, condensate, corrosive gas, explosive gas, oil dirt, dust, and metal powder etc.

2.1.2 Installation Space and Distance

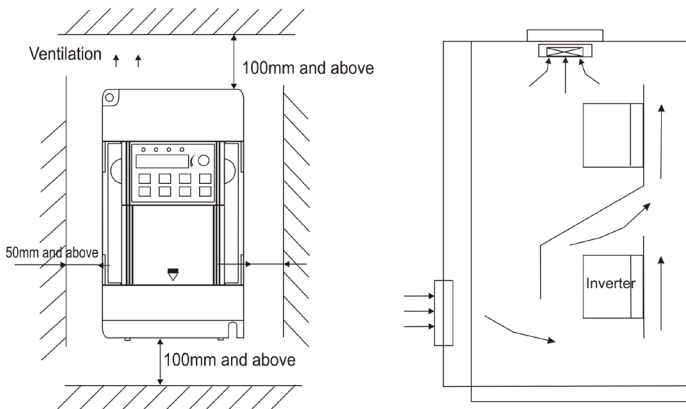

When take up-down installation, air deflector should be installed between upper inverter and lower inverter.

2.1.3 Drawing of Moving the Front Cover

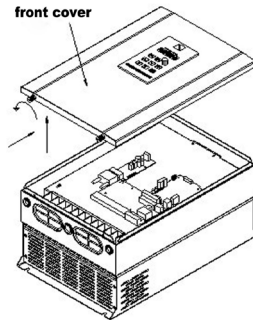

2.2 Electric Installation

2.2.1 Connecting of Peripheral Equipments

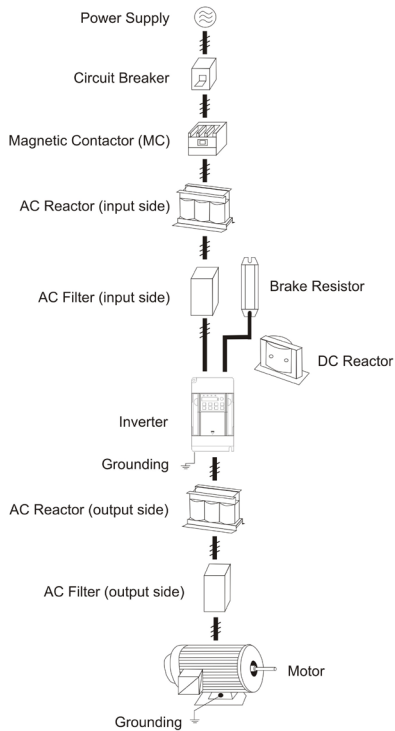

2.2.2 Recommended Table of External Electrical Parts

Inverter Model	Circuit Breaker (MCCB) (A)	Recommended Contactor (A)	Conducting Wire of Main Circuit at the Input Side (mm ²)	Conducting Wire of Main Circuit at the Input Side (mm ²)	Conducting Wire of Control Circuit (mm ²)
8000B-2SR75GB	16	10	2.5	2.5	1.0
8000B-2S1R5GB	20	16	4.0	2.5	1.0
8000B-2S2R2GB	32	20	6.0	4.0	1.0
8000B-4TR75GB	10	10	2.5	2.5	1.0
8000B-4T1R5GB	16	10	2.5	2.5	1.0
8000B-4T2R2GB	16	10	2.5	2.5	1.0
8000B-4T004GB/4T5R5PB	25	16	4.0	4.0	1.0
8000B-4T5R5GB/4T7R5PB	32	25	4.0	4.0	1.0
8000B-4T7R5GB	40	32	4.0	4.0	1.0
8000B-4T011GB/4T015PB	63	40	4.0	4.0	1.0
8000B-4T015GB/4T18R5PB	63	40	6.0	6.0	1.0
8000B-4T18R5GB	100	63	6.0	6.0	1.5
8000B-4T022G/4T030P	100	63	10	10	1.5
8000B-4T030G/4T037P	125	100	16	10	1.5
8000B-4T037G	160	100	16	16	1.5
8000B-4T045G/4T055P	200	125	25	25	1.5
8000B-4T055G/4T075P	200	125	35	25	1.5
8000B-4T075G/4T093P	250	160	50	35	1.5
8000B-4T093G/4T110P	250	160	70	35	1.5
8000B-4T110G	350	350	120	120	1.5
8000B-4T132G/4T160P	400	400	150	150	1.5
8000B-4T160G/4T185P	500	400	185	185	1.5
8000B-4T185G	600	600	150*2	150*2	1.5
8000B-4T200G/4T220P	600	600	150*2	150*2	1.5
8000B-4T220G/4T250P	600	600	150*2	150*2	1.5
8000B-4T250G/4T280P	800	600	185*2	185*2	1.5
8000B-4T280G/4T315P	800	800	185*2	185*2	1.5
8000B-4T315G	800	800	150*3	150*3	1.5
8000B-4T350G	800	800	150*4	150*4	1.5
8000B-4T400G	1000	1000	150*	150*4	1.5

2.2.3 Recommended Table of Reactor

Inverter Model	AC Reactor at the Input Side		AC Reactor at the output Side		DC Reactor		Voltage
	Current (A)	Inductance (mH)	Current (A)	Inductance (mH)	Current (A)	Inductance (mH)	
8000B-2SR75GB	2	7	2	7	3	28	220V
8000B-2S1R5GB	5	3.8	5	3.8	6	11	
8000B-2S2R2GB	7.5	2.5	7.5	2.5	6	11	
8000B-4TR75GB	2	7	2	3	3	28	380V
8000B-4T1R5GB	5	3.8	5	1.5	6	11	
8000B-4T2R2GB	7	2.5	7	1	6	11	
8000B-4T004GB/4T5R5PB	10	1.5	10	0.6	12	6.3	
8000B-4T5R5GB/4T7R5PB	15	1.0	15	0.25	23	3.6	
8000B-4T7R5GB	20	0.75	20	0.13	23	3.6	
8000B-4T011GB/4T015PB	30	0.60	30	0.087	33	2	
8000B-4T015GB/4T18R5PB	40	0.42	40	0.066	33	2	
8000B-4T18R5GB	50	0.35	50	0.052	40	1.3	
8000B-4T022G/4T030P	60	0.28	60	0.045	50	1.08	
8000B-4T030G/4T037P	80	0.19	80	0.032	65	0.80	
8000B-4T037G	90	0.16	90	0.030	78	0.70	
8000B-4T045G/4T055P	120	0.13	120	0.023	95	0.54	
8000B-4T055G/4T075P	150	0.10	150	0.019	115	0.45	
8000B-4T075G/4T093P	200	0.08	200	0.014	160	0.36	
8000B-4T093G/4T110P	250	0.06	250	0.011	180	0.33	
8000B-4T110G	250	0.06	250	0.011	250	0.26	
8000B-4T132G/4T160P	290	0.04	290	0.008	250	0.26	
8000B-4T160G/4T185P	330	0.04	330	0.008	340	0.18	
8000B-4T185G	400	0.04	400	0.005	460	0.12	
8000B-4T200G/4T220P	490	0.03	490	0.004	460	0.12	
8000B-4T220G/4T250P	490	0.03	490	0.004	460	0.12	
8000B-4T250G/4T280P	530	0.03	530	0.003	650	0.11	
8000B-4T280G/4T315P	600	0.02	600	0.003	650	0.11	
8000B-4T315G	660	0.02	660	0.002	800	0.06	
8000B-4T350G	400*2	0.04	400*2	0.005	460*2	0.12	
8000B-4T400G	490*2	0.03	490*2	0.004	460*2	0.12	

2.2.4 Descriptions of External Electrical Parts

Name	Mounting Location	Function
Circuit Breaker	Front end of input circuit	Disconnect the power supply when the backward equipment is over current.
Contactor	Between the circuit breaker and inverter input side	Power ON/OFF of inverter. Do not use the contactor as the switch of inverter. Otherwise, it may cause damage to the inverter.
AC Reactor at the Input Side	Input side of inverter	<ol style="list-style-type: none"> 1. Improve the power factor of the input side. 2. Eliminate the harmonic wave at the input side effectively and prevent other equipment from damage. 3. Eliminate the input current unbalance caused by unbalance between the power phases.
EMC Input Filter	Input side of inverter	<ol style="list-style-type: none"> 1. Reduce the external conduction and radiation interference of inverter. 2. Decrease the conduction interference flowing from the power end to the inverter and improve the anti-interference capacity of the inverter.
DC Reactor	Additional parts of 8000B series inverter	<ol style="list-style-type: none"> 1. Improve the power factor at the input side. 2. Improve the whole efficiency and thermal stability of the inverter. 3. Eliminate the impact of higher harmonics at the input side on the inverter and reduce the external conduction and radiation interference.
AC Reactor at the Output Side	Between inverter output side and motor. Close to inverter.	<p>The inverter output side generally has higher harmonics. When the motor is far from inverter, since there are many distributed capacitors in the circuit, certain harmonics may cause resonance in the circuit and bring the following two impacts:</p> <ol style="list-style-type: none"> 1. Degrade the motor insulation performance and damage the motor when running for long time. 2. Generate large leakage current and cause frequent inverter protection. <p>Generally, installation of output AC reactor is recommended when the distance between inverter and motor exceeds 50m.</p>

Chapter 3 Wiring

3.1 Standard Wiring Diagram

3.1.1 Wiring Diagram of 0.75kW~2.2kW (model G) (3-phase,380V)

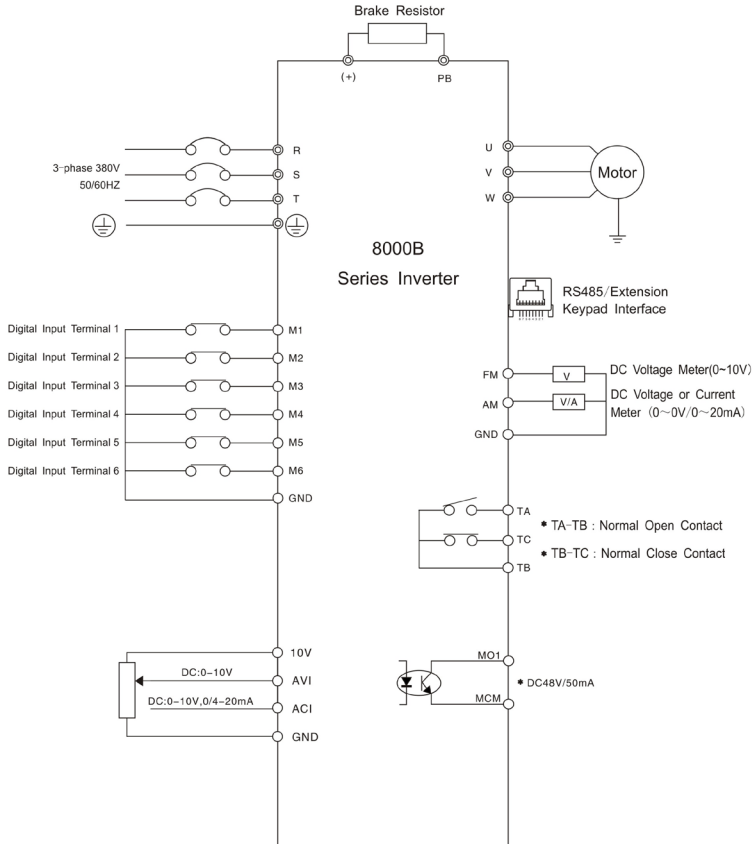

Note:

1. ◎ refers to terminals of main circuit; ○ refers to terminals of control circuit.
2. 0.75kW~2.2kW (model G) : brake unit is standard part inside.
3. 0.75kW~2.2kW (model G) of single-phase/220V: main circuit terminals are R and T.

3.1.2 Wiring Diagram of 4kW~7.5kW (model G) (3-phase,380V)

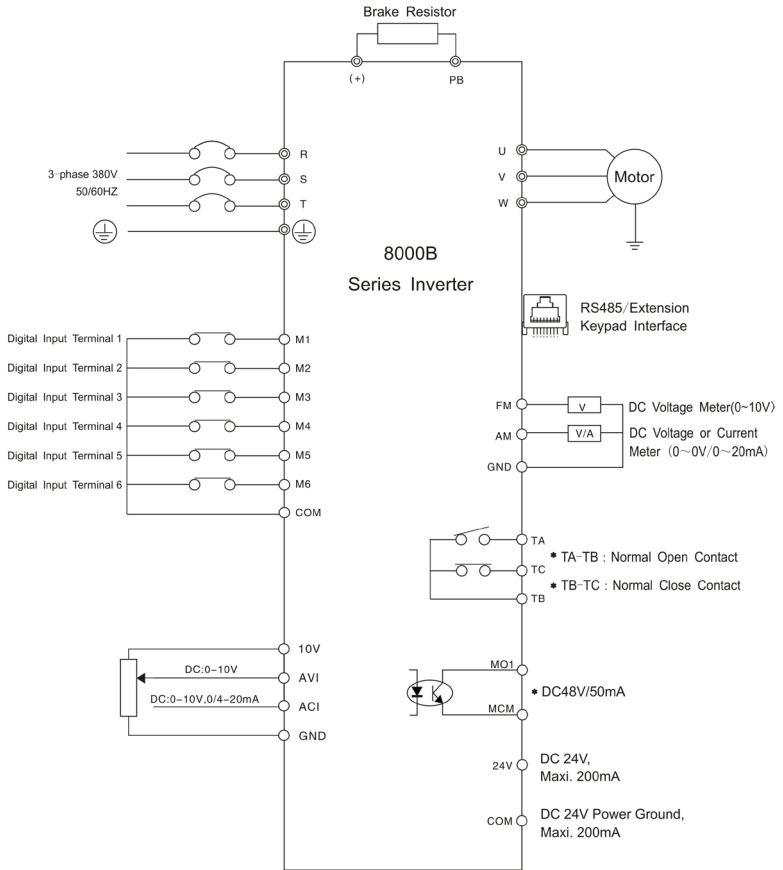

Note:

1. ◎ refers to terminals of main circuit; ○ refers to terminals of control circuit.
2. 4kW~7.5kW (model G) : brake unit is standard part inside.

3.1.3 Wiring Diagram of 11kW~18.5kW (model G) (3-phase,380V)

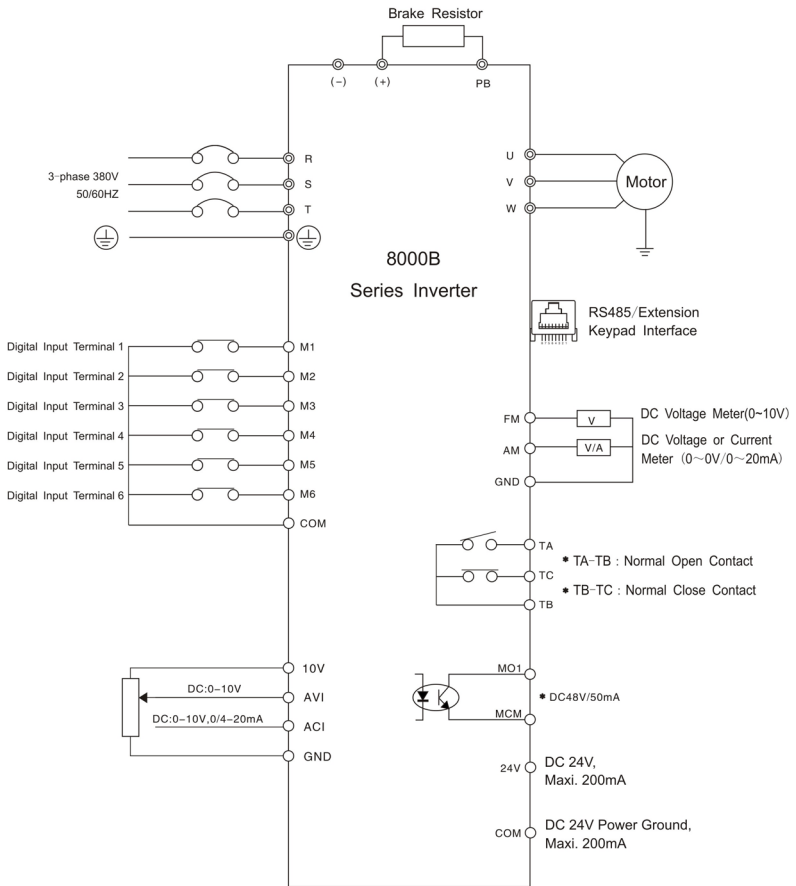

Note:

1. © refers to terminals of main circuit; ○ refers to terminals of control circuit.
2. 11kW~18.5kW (model G) : brake unit is standard part inside.

3.1.4 Wiring Diagram of 22kW~400kW (model G) (3-phase,380V)

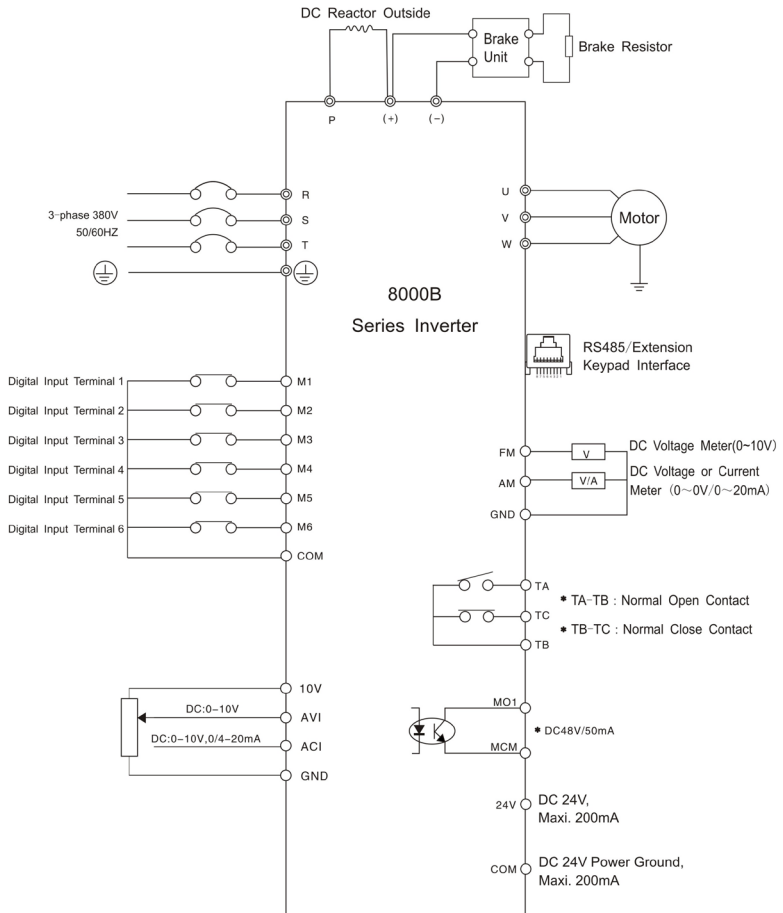

Note:

1. ◎ refers to terminals of main circuit; ○ refers to terminals of control circuit.
2. 22kW~400kW (model G) : brake unit is additional part outside.
3. 22kW~400kW (model G) : DC reactor is additional part outside.

3.2 Terminal Descriptions of Main Circuit and Control Circuit

3.2.1 Main Circuit Terminals:

(1) Main circuit terminals (0.75kW~2.2kW (model G) with built-in brake unit)



(2) Main circuit terminals (4kW~7.5kW (model G) with built-in brake unit)

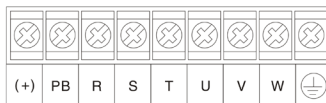

(3) Main circuit terminals (11kW~18.5kW (model G) with built-in brake unit)



(4) Main circuit terminals (22kW~37kW (model G))



(5) Main circuit terminals (45kW~110kW (model G))



(6) Main circuit terminals (132kW~400kW (model G))

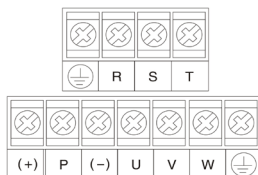

Terminals	Descriptions
R, S, T	Terminals of AC power input.
U, V, W	Terminals of AC power output
(+), (-)	Spare terminals for connecting external brake unit.
P	Spare terminal for connecting external DC reactor.
PB	Spare terminal for connecting external brake resistor.
	Grounding terminal

3.2.2 Precautions on Main Circuit Wiring

3.2.2.1 Terminals R, S and T

The wiring at the input side of inverter has no phase sequence requirement. When input single-phase power, use terminal R and T.

3.2.2.2 DC Bus Terminals (+) and (-)

The (+) and (-) terminals of DC bus have residual voltage right after power-off. Wait until the CHARGE indicator is OFF and make sure that the voltage is less than 36V before wiring. Otherwise it may cause electrical shock.

When use external brake unit for inverter of 22kW and above, the poles of (+) and (-) should not be connected reversely. Otherwise, it may cause damage to inverter and even cause fire.

The cable length of brake unit should be less than 10m. Use twisted pair cable or connect in parallel.

Do not connect brake resistor directly to the DC bus. Otherwise, it may cause damage to inverter and even cause fire.

3.2.2.3 Terminals (+) and PB of Brake Resistor

The terminals of brake resistor are effective only for inverter of 18.5kW and below with built-in brake unit.

The cable length of brake resistor should be less than 5m.

3.2.2.4 Terminals P and (+) of External Reactor

For inverter of 22kW and above, the reactor is additional part which is connected externally.

3.2.2.5 Terminals U, V and W

Capacitor device or surge absorber can not be connected to inverter output side by terminals U, V and W. Otherwise, it may cause frequent inverter protection or damage to inverter.

If motor cable is too long, it may generate electrical resonance easily due to the impact of distributed capacitance and thus damage the motor insulation or generate higher leakage current to cause inverter protection. When the length of motor cable is longer than 50m, installing AC reactor at the output side is necessary.

3.2.2.6 Grounding Terminal \oplus

The terminal \oplus should be grounded reliably. The resistance value of grounding cable should be less than 10 Ω . Otherwise, it may cause fault or damage to the inverter.

Do not share the grounding terminal with zero line of power supply.

3.2.3 Control Circuit Terminals

0.75kW~2.2kW Control Circuit Terminals

TA	TB	TC	M1	M2	M3	M4	M5	M6	GND	FM	AM	ACI	10V	AVI	GND	MCM	MO1
----	----	----	----	----	----	----	----	----	-----	----	----	-----	-----	-----	-----	-----	-----

4kW~400kW Control Circuit Terminals

M1	M2	M3	COM	M4	M5	M6	COM	24V
MO1	MCM	AVI	ACI	10V	GND	GND	FM	AM
TA	TB	TC						

Communication Terminals

1	2	3	4	5	6	7	8
S+	S-	+15V	GND	+5V	NC	+5V	GND

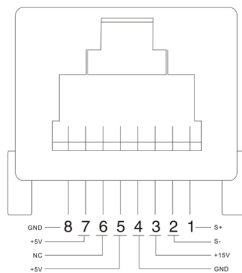

Type	Terminal Symbol	Function	Interface Standard
Computer Communication	S+	485 difference signal positive terminal	Standard RS485 communication interface
	S-	485 difference signal negative terminal	
	+5V	Extension power positive terminal (+5V)	
	+15V	Extension power positive terminal(+15V)	
	GND	Extension power negative terminal	

3.2.4 Descriptions of Control Circuit Terminals

Symbol	Terminal Name	Function
M1~M6	Multi-function digital input terminal	0.75-2.2kW (G): Digital terminals can not be connected to power directly. When connected to GND terminal, it is power-on and the corresponding current is 10mA. 4kW and above: Optical coupling isolation input compatible with +24V and COM. Input voltage range:9-36V, input impedance:3.3k Ω
MO1	Multi-function output terminal	(optical coupling isolating)Max. DC 48V/50mA
MCM	Common terminal of multi-function output terminal	(optical coupling isolating)Max. DC 48V/50mA
AVI	Analog input terminal 1	Input voltage range:DC 0~10V (input impedance:20k Ω)
ACI	Analog input terminal 2	1. input range:DC 0-10V or 0/4~20mA. It is selected by jumper JP1 on control board. The default is current input. 1-2Pin: voltage input; 2-3Pin: current input. 2. Input impedance:20k Ω when input voltage; 500 Ω when input current.
10V	Analog reference voltage	10V \pm 5%,max. current: 30mA
GND	Analog grounding terminal	Zero potential referring to +10V
FM	Analog output terminal 1	FM:0~10V

AM	Analog output terminal 2	Output range: 0~10V or 0/4-20mA. It is selected by jumper JP2 on control board. The default is current output. 1-2Pin: current output; 2-3Pin: voltage output. 0.75~2.2kW:0/4~20mA. 4~400kW:0~10V / 0/4~20mA.
TA/TB/TC	Relay output contact	TA-TB:normal open;TB-TC:normal close Contact capacity: AC 250V / 3A/ normal open AC 250V / 3A / normal close
+24V	+24V power supply	Output current: Maxi. 200mA,usually used as power of digital input/output terminals and external sensor.
COM	+24V power supply	Output current: Maxi. 200mA,usually used as power of digital input/output terminals and external sensor.

3.2.5 Precautions for Connecting Control Circuit Terminals

It is necessary to use shielded cable and twisted pair cable with well-grounded (inverter side). The cable length should be more than 20cm away from main circuit and strong electricity circuit. In order to avoid interference which can cause inverter fault, use vertical connection instead of parallel connection.

Chapter 4 Operation

4.1 Keypad Description

4.1.1 Keypad Schematic Diagram

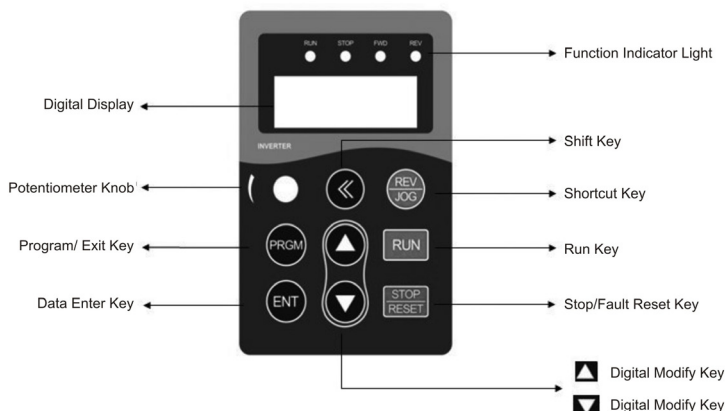

4.1.2 Key Function Description

Symbol	Key Name	Function Description
PRGM	Program/ Exit key	Enter or exit of menu, parameter modification
ENT	Data enter key	Progressively enter menu and confirm parameter.
▲	UP increase key	Progressively increase data or function codes.
▼	DOWN decrease key	Progressively decrease data or function codes.
≡	Shift key	Use it to select displayed parameters cyclically during running or stop status. In parameter setting mode, press this key to select the bit to be modified.
RUN	Run key	Start to run the inverter in keypad control mode.
STOP/ RESET	Stop/reset key	In running status, restricted by function code F7.04, it can be used to stop the inverter, In malfunction alarm status, not restricted by function code F7.04, it can be used to reset the inverter.
REV/JOG	Shortcut key	Determined by function code F7.03.

4.1.3 Indicator Light Description

Indicator Light Name	Description
RUN	Light on: inverter running status.
STOP	Light on: inverter stops or malfunction status.
FWD	Lights of FWD and RUN are on at the same time: inverter forward running status.
REV	Lights of REV and RUN are on at the same time: inverter reversely running status.

4.2 Operation Process

4.2.1 Parameter Setting

Three levels of menu are as following:

- Function code group (first-class)
- Function code (second-class)
- Setting parameter of function code (third-class)

Remarks:

Pressing **PRGM** or **ENT** can return to the second-class menu from the third-class menu. The difference is: Pressing **ENT** will save the setting parameters into control board, and return to the second-class menu with shifting to the next function code automatically. While pressing **PRGM** will directly return to the second-class menu without saving the parameters, and keep staying at the current function code.

For example: change the parameter 00.50Hz of function code F1.01 into 05.00Hz as the following flow chart shows:

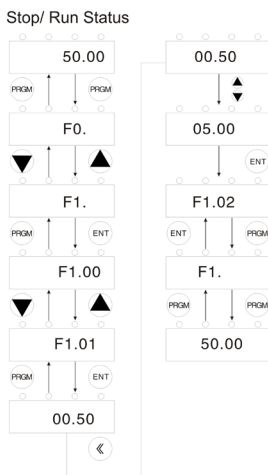

Flow Chart of Parameter Setting

Under the third-class menu, if the parameter has no flickering bit, it means that the function code cannot be modified. The possible reasons include:

- (1) The parameter of this function code can't be modified, such as actually detected parameter, operation records and so on.
- (2) This function code can't be modified during running status, but can be modified during stop status.

4.2.2 Fault Reset

When inverter malfunction occurs, it will display the relative fault information. Use the STOP/ RESET key or terminals (determined by F5 group) to reset the fault. After fault reset, inverter is at stand-by status. If not reset when inverter is at fault status, it will keep operation protection status and cannot run.

4.2.3 Motor Parameter Autotuning

When select SVC control mode (sensorless vector control), make sure that motor nameplate parameters are correctly input into the inverter. Inverter will match standard motor parameter according to nameplate parameter. In order to achieve precise control, autotuning is necessary. Refer to the following steps:

Firstly, set the parameter of F0.01 to 0. This means that select the keypad to control stop or start. Then input the following parameters according to the motor nameplate:

- F2.01: Motor rated power
- F2.02: Motor rated frequency
- F2.03: Motor rated rotation speed
- F2.04: Motor rated voltage
- F2.05: Motor rated current

Remarks:

If motor can be uncoupled with its load completely, set the parameter of F2.11 to 1 (complete tuning) and then push RUN key, inverter can calculate the parameter of motor. During autotuning process, the panel of inverter will display -RUN-. When it displays -END-, the autotuning process is finished.

If motor cannot be uncoupled with its load, set the parameter of F2.11 to 2 (static tuning) and push RUN key, inverter will auto-detect the parameters

of motor stator resistor, rotor resistor and leakage inductance, while the parameters of motor mutual inductance and no-load current are not detected. The parameters of motor mutual inductance and no-load current can be calculated by the following formula:

$$I_0 = I \times \sqrt{1 - \eta^2}$$

$$L_m = \frac{U}{2\sqrt{3} \pi f \cdot I_0} - L_\delta$$

I_0 : motor no-load current

L_m : motor mutual inductance

L_δ : motor leakage inductance

U : motor rated voltage

I : motor rated current

f : motor rated frequency

η : motor power factor

4.2.4 Password Setting

When F7.00 is set to be non-zero, the parameter will be the user's password. After exit the function code editing status, the password will be effective after one minute. And then press the PRGM key again to try to access the function code editing mode, the inverter panel will display "0.0.0.0". The password must be input correctly to access it. If it is necessary to cancel the password function, set F7.00 to zero.

Notice:

When the inverter is powered on, system will execute initialization first and inverter panel displays "8000" with four lights on. After initialization, inverter accesses into stand-by status.

Chapter 5 Function Code Table

Notice:

“○” : The parameters can be modified at stop or running status.

“◎” : The parameters cannot be modified at running status.

“●” : The parameters which are actual-detecting record value cannot be modified.

Function Code	Function	Descriptions	Minimum Unit	Factory Setting	Modification Type
F0 Group: Basic Parameters					
F0.00	Control mode selection	0: Sensorless vector control 1:V/F control		1	●
F0.01	Run command source	0:Keypad 1:Terminals 2: Communications (RS485)		0	●
F0.02	Setting value valid or not of keypad / terminals	0: Valid and saved when power-off 1:Valid and not saved when power-off 2: Invalid 3. Valid at running status. Changed into the setting value of F0.08 when restart after stop.		0	○
F0.03	Master frequency setting source X	0: Up/down key 1: Potentiometer of panel 2: AVI terminal 3: ACI terminal 4: Reserved 5: Reserved 6: Multi-function digital input terminals 7: PLC 8: PID 9: Communication interface		1	●
F0.04	Auxiliary frequency setting source Y	0: AVI terminal 1: ACI terminal 2: Reserved		1	●

Function Code	Function	Descriptions	Minimum Unit	Factory Setting	Modification Type
F0.05	Range of auxiliary frequency setting source Y	0: Relative to the maxi. frequency 1: Relative to master frequency setting source X		0	●
F0.06	Reserved				
F0.07	Frequency setting source selection	0:X 1: Y 2: X and Y 3: Max. value of (X, Y)		0	○
F0.08	Keypad setting frequency	0.00Hz~ F0.10	0.01Hz	50.00 Hz	○
F0.09	Running direction selection	0: Forward 1: Reverse 2: Reverse running prohibited		0	●
F0.10	Max. output frequency	10.00~600.00Hz	0.01Hz	50.00Hz	●
F0.11	Upper limit frequency setting source	0:Keypad (F0.12) 1:AVI terminal 2: ACI terminal 3: Multi-function digital input terminals 4: Communication interface		0	○
F0.12	Upper limit of running frequency	F0.14~ F0.10	0.01Hz	50.00Hz	○
F0.13	Reserved				
F0.14	Lower limit of running frequency	0.00Hz~ F0.12	0.01Hz	0.00Hz	○

Function Code	Function	Descriptions	Minimum Unit	Factory Setting	Modification Type
F0.15	The function of lower limit frequency	0: Running at lower limit frequency 1: Stop frequency point 2: Sleep frequency point		0	○
F0.16	Carrier frequency	1.0~15.0kHz	1kHz	Different according to the inverter type	○
F0.17	PWM mode selection	0:PWM mode 1 1:PWM mode 2 2:PWM mode 3		0	●
F0.18	Acceleration time 1	0.1~3600.0s	0.1s	Different according to the inverter type	○
F0.19	Deceleration time 1	0.1~3600.0s	0.1s	Different according to the inverter type s	○
F0.20	Default setting	0:No operation 1: Restore to factory setting 2:Fault record clearing		0	●
F0.21	Parameter lock setting	0: Unlock parameter 1: Lock parameter		0	○
F0.22	Acceleration/ deceleration method	0: Linear method 1: Reserved		0	●
F0.23	Reserved				
F0.24	Reserved				

Function Code	Function	Descriptions	Minimum Unit	Factory Setting	Modification Type
F0.25	Cooling fan running method (only for 4kW and above inverter)	0: Keep running when power on 1: Automatic running		1	○
F1 Group: Start and Stop Parameters					
F1.00	Start mode	0:Start directly 1:DC braking first and then start 2:Speed tracing and start		0	●
F1.01	Start frequency	0.00~10.00Hz	0.01Hz	1.50Hz	○
F1.02	Hold time of start frequency	0.0~50.0s	0.1s	0.0s	○
F1.03	DC braking current before start	0.0~150.0%	0.1%	0.0%	○
F1.04	DC braking time before start	0.0~50.0s	0.1s	0.0s	○
F1.05	Stop mode	0: Deceleration to stop 1: Coast to stop		0	○
F1.06	Starting frequency of DC braking	0.00~ F0.10	0.01Hz	0.00Hz	○
F1.07	Waiting time before DC braking	0.0~50.0s	0.1s	0.0s	○
F1.08	DC braking current	0.0~150.0%	0.1%	0.0%	○

Function Code	Function	Descriptions	Minimum Unit	Factory Setting	Modification Type
F1.09	DC braking time	0.0~50.0s	0.1s	0.0s	○
F1.10	Dead time between FWD and REV	0.0~3600.0s	0.1s	0.0s	○
F1.11	Terminals enable option when power on	0: Disabled 1: Enabled		1	○
F1.12 ~ F1.17	Reserved				
F1.18	Wake-up time delay	0.0~3600s	0.1s	0.0s	○
F1.19	Restart option after power-off	0: Disabled 1: Enabled		0	○
F1.20	Waiting time of restart	0.0~3600s	0.1s	0.0s	○
F1.21	Over modulation option	0: Disabled 1: Enabled		0	○
F2 Group: Motor Parameters					
F2.00	Inverter model	0: General model (G) 1: Pump model (P)		0	●
F2.01	Motor rated power	0.4~700.0kW	0.1kW	Different according to inverter model	●
F2.02	Motor rated frequency	10.00Hz~ F0.10	0.01Hz	50.00Hz	●

Function Code	Function	Descriptions	Minimum Unit	Factory Setting	Modification Type	
F2.03	Motor rated rotation speed	0~36000rpm	1rpm	Different according to inverter model	●	
F2.04	Motor rated voltage	0~480V	1V		●	
F2.05	Motor rated current	0.8~2000A	0.1A		●	
F2.06	Motor stator resistance	0.001~65.53Ω	0.001Ω		○	
F2.07	Motor rotor resistance	0.001~65.53Ω	0.001Ω		○	
F2.08	Motor stator inductance	0.1~6553mH	0.1mH		○	
F2.09	Motor rotor mutual inductance	0.1~6553mH	0.1mH		○	
F2.10	Motor no-load current	0.1~655.3A	A		○	
F2.11	Motor parameters autotuning	0:No autotuning 1:Autotuning completely(no load) 2:Static autotuning(with load)			0	●
F2.12	Reserved					
F3 Group: Vector Control Parameters						
F3.00	Proportional gain 1 of speed loop	0~100		20	○	
F3.01	Integral time 1 of speed loop	0.01~10.00s	0.01s	0.50s	○	
F3.02	Low frequency point of switch	0.00Hz~F3.05	0.01Hz	5.00Hz	○	

Function Code	Function	Descriptions	Minimum Unit	Factory Setting	Modification Type
F3.03	Proportional gain 2 of speed loop	0~100	1	25	○
F3.04	Integral time 2 of speed loop	0.01~10.00s	0.01s	1.00s	○
F3.05	High frequency point of switch	F3.02~F0.10	1Hz	10.00Hz	○
F3.06	Coefficient of slip compensation at VC control mode	50~200%	1%	100%	○
F3.07	Upper limit torque	0.0~200.0% (inverter rated current)	0.1%	150.0%	○
F3.08	Reserved				
F3.09	Reserved				
F3.10	Pre-alarm option when overload	0: Not detect 1: Effective during running and keep running after alarm 2: Effective during running and stop after alarm (fault code:E023) 3: Effective during constant running and keep running after alarm 4: Effective during constant running and stop after alarm		1	○
F3.11	Detecting level of pre-alarm when overload	1.0~200.0% (referred to inverter rated current)	0.1%	150.0%	○
F3.12	Detecting time of pre-alarm when overload	0~600s	1s	1s	○

Function Code	Function	Descriptions	Minimum Unit	Factory Setting	Modification Type
F4 Group: V/F Control Parameters					
F4.00	V/F curve selection	0: Linear curve 1: User-defined curve 2: 1.3 square torque-step-down curve 3: 1.7 square torque-step-down curve 4: 2 square torque-step-down curve		0	●
F4.01	Torque boost	0.0 %(auto) 0.1%~30.0%	0.1%	1.0%	○
F4.02	Torque boost cut-off frequency	0.0~50.0% (relative to motor rated frequency)	0.1%	20.0%	●
F4.03	V/F frequency 1	0.00Hz~F4.05	0.01Hz	0.00Hz	●
F4.04	V/F voltage 1	0.0%~100.0%	0.1%	0.0%	●
F4.05	V/F frequency 2	F4.03~F4.07	0.01Hz	25.00Hz	●
F4.06	V/F voltage 2	0.0%~100.0%	0.1%	50.0%	●
F4.07	V/F frequency 3	F4.05~motor rated frequency	0.01Hz	50.00Hz	●
F4.08	V/F voltage 3	0.0%~100.0%	0.1%	100.0%	●
F4.09	Coefficient of V/F Slip compensation	0.0%~200.0%	0.1%	0.0%	○
F4.10	Energy-saving selection	0:Disabled 1:Enabled automatically		0	○
F4.11	Reserved				

Function Code	Function	Descriptions	Minimum Unit	Factory Setting	Modification Type
F4.12	Low-frequency threshold of restraining oscillation	0~10		2	○
F4.13	High-frequency threshold of restraining oscillation	0~10		0	○
F4.14	Reserved				
F4.15	Boundary frequency of restraining oscillation	0.00Hz~F0.10 (Maxi. frequency)	0.01Hz	30.00Hz	○
F4.16	Reserved				
F4.17	AVR function selection	0:Invalid 1:Valid all the time 2: Only invalid during deceleration		1	○
F5 Group: Input Terminals Parameters					
F5.00	M1 terminal function	0:Invalid 1:Forward run (FWD) 2:Reverse run (REV) 3:3-wire control 4:Forward jog run (FJOG) 5:Reverse jog run (RJOG) 6: Coast to stop 7: Fault reset (RESET) 8: Pause running 9: External fault input N. O. 10: UP Key command 11: DOWN Key command 12: Clear UP/DOWN setting		1	●
F5.01	M2 terminal function			2	●

Function Code	Function	Descriptions	Minimum Unit	Factory Setting	Modification Type
F5.02	M3 terminal function	13: Frequency setting source switch between X and Y 14: Frequency setting source switch between X and (X+ Y) 15: Frequency setting source switch between Y and (X+ Y) 16: Multi-step speed terminal 1 17: Multi-step speed terminal 2 18: Multi-step speed terminal 3 19: Multi-step speed terminal 4		7	●
F5.03	M4 terminal function	20: Multi-step speed pause 21: Acceleration/deceleration time selection terminal 1 22: Acceleration/deceleration time selection terminal 2 23: Reset simple PLC after pause 24: Simple PLC pause 25: PID pause		0	●
F5.04	M5 terminal function	26: Swing frequency pause (stop at current frequency) 27: Reset after swing frequency pause (reset to central frequency) 28: Counter reset 29:Reserved 30:Acceleration/deceleration prohibited		0	●
F5.05	M6 terminal function	31:Counter triggering 32:Clear UP/DOWN setting temporarily 33: Reserved 34: Counting meter input 35: Counting meter clear up 36: Command source switch 37: Terminal input delay output 38: Reserved		0	●

Function Code	Function	Descriptions	Minimum Unit	Factory Setting	Modification Type
F5.06 ~ F5.09	Reserved				
F5.10	On/off filter times	1~10		5	○
F5.11	FWD/ REV control mode	0:2-wire control mode 1 2:2-wire control mode 2 3:3-wire control mode 1 4:3-wire control mode 2		0	●
F5.12	Frequency change rate when UP/DOWN setting	0.01~50.00Hz/s	0.01Hz/s	0.50Hz/s	○
F5.13	AVI lower limit	0.00V~10.00V	0.01V	0.00V	○
F5.14	AVI lower limit corresponding to setting value	-100.0%~100.0%	0.1%	0.0%	○
F5.15	AVI upper limit	0.00V~10.00V	0.01V	10.00V	○
F5.16	AVI upper limit corresponding to setting value	-100.0%~100.0%	0.1%	100.0%	○
F5.17	AVI input filter time	0.00s~10.00s	0.01s	0.10s	○
F5.18	ACI lower limit	0.0mA~20.0mA	0.1mA	4.0mA	○
F5.19	ACI lower limit corresponding to setting value	-100.0%~100.0%	0.1%	0.0%	○
F5.20	ACI upper limit	0.0mA~20.0mA	0.1mA	20.0mA	○

Function Code	Function	Descriptions	Minimum Unit	Factory Setting	Modification Type
F5.21	ACI upper limit corresponding to setting value	-100.0%~100.0%	0.1%	100.0%	○
F5.22	ACI input filter time	0.00s~10.00s	0.1s	0.10s	○
F5.23 ~ F5.32	Reserved				
F6 Group: Output Terminals Parameters					
F6.00	MO1 output selection	0:No output		1	○
F6.01	Reserved	1:Motor forward running 2:Motor reverse running 3:Fault output		0	○
F6.02	Relay 1 output selection	4: Frequency detecting level FDT output 5:Frequency reached		3	○
F6.03	Relay 2 output selection	6:Running at zero speed 7:Upper limit frequency reached 8:Lower limit frequency reached 9:Frequency setting value less than lower limit frequency 10:FDT reached 11:Accumulative running time reached 12:PLC cycle completed 13:Pre-alarm when overload 14>User define output 15:Running frequency detection 16:Terminal input delay 17:Inverter stand-by		0	○

Function Code	Function	Descriptions	Minimum Unit	Factory Setting	Modification Type
F6.04	FM output selection	0:Running frequency 1:Setting frequency 2:Running rotation speed 3:Output current 4:Output voltage 5:Reserved 6:Reserved 7:Reserved 8: Analog AVI input value 9: Analog ACI input value		0	○
F6.05	FM output lower limit	0.0~100.0%	0.1%	0.0%	○
F6.06	FM lower limit corresponding to output	0.00V~10.00V	0.01V	0.00V	○
F6.07	FM output upper limit	0.0~100.0%	0.1%	100.0%	○
F6.08	FM upper limit corresponding to output	0.00V~10.00V	0.01V	10.00V	○
F6.09	AM output selection	0:Running frequency 1:Setting frequency 2:Running rotation speed 3:Output current 4:Output voltage 5:Reserved 6:Reserved 7:Reserved 8: Analog AVI input value 9: Analog ACI input value		0	○
F6.10	AM output lower limit	0.0~100.0%	0.1%	0.0%	○
F6.11	AM lower limit corresponding to output	0.00V~10.00V	0.01V	0.00V	○

Function Code	Function	Descriptions	Minimum Unit	Factory Setting	Modification Type
F6.12	AM output upper limit	0.0~100.0%	0.1%	100.0%	○
F6.13	AM upper limit corresponding to output	0.00V~10.00V	0.01V	10.00V	○
F6.14	User defined output variability option (EX)	0:Running frequency 1:Setting frequency 2:DC bus voltage 3:Output current 4:Output voltage 5:Sign of start and stop status 6:Sign of control status 7:Counter value 8:Counting meter value 9:Inverter module temperature 10:AVI input value 11:ACI input value		0	○
F6.15	Comparison method of user defined output	Units digit: comparison test method 0: equal (EX=X1) 1: equal or greater than 2: equal or less than 3: interval comparison (X1≤EX≤X2) 4:units digit test (EX&X1=X2) Tens digit : output method 0 : false value output 1: real value output		00	○
F6.16	User defined dead interval	0~65535		0	○
F6.17	Output comparison value X1	0~65535		0	○
F6.18	Output comparison value X2	0~65535		0	○

Function Code	Function	Descriptions	Minimum Unit	Factory Setting	Modification Type
F7 Group: Display Interface Parameters					
F7.00	User password	0~9999		0	○
F7.01	Reserved				
F7.02	Reserved				
F7.03	REV/JOG key function selection	0:Switch display status 1:Clear UP/DOWN setting 2:Reverse running 3:Forward jog running 4:Quick debugging mode		2	●
F7.04	Stop function selection of STOP/RESET key	0:Only valid for keypad setting 1:Valid for both keypad setting and terminals setting 2:Valid for both keypad setting and communication interface setting 3:Valid for all control mode		0	○
F7.05	Reserved				
F7.06	Running status display selection 1	0~0xFFFF BIT0:Running frequency BIT1:Setting frequency BIT2:DC bus voltage BIT3:Output voltage BIT4:Output current BIT5:Running speed BIT6:Linear speed BIT7:Reserved BIT8:Reserved BIT9:PID setting value BIT10:PID feedback value BIT11:Input terminals status BIT12:Output terminals status BIT13:Reserved BIT14:Counter value BIT15:Current step of multi-step speed and PLC		35	○

Function Code	Function	Descriptions	Minimum Unit	Factory Setting	Modification Type
F7.07	Running status display selection 2	1~0xFFFF BIT0:AVI value BIT1: ACI value BIT2:Reserved BIT3: Motor overload ratio BIT4: Inverter overload ratio BIT5:Running time BIT6:Counting meter value BIT7~BIT15: Reserved		0	○
F7.08	Stop status display selection	0~0xFFFF BIT0: Setting frequency BIT1: DC bus voltage BIT2:Input terminal status BIT3:Output terminal status BIT4:PID setting value BIT5:PID feedback value BIT6:AVI value BIT7:ACI value BIT8:Reserved BIT9: Current step of multi-step speed and PLC BIT10:Reserved BIT11:Counting meter value BIT12~BIT15:Reserved		3	○
F7.09	Inverter module temperature	0~100℃	1℃		◎
F7.10	Inverter software version				◎
F7.11	Accumulative running time	0~9999h	1hour		◎
F7.12	Accumulative power-on time	0~9999h	1hour		◎
F7.13	Reserved				

Function Code	Function	Descriptions	Minimum Unit	Factory Setting	Modification Type
F8 Group: Auxiliary Function Parameters					
F8.00	Jog running frequency	0.00~F0.10	0.01Hz	5.00Hz	○
F8.01	Jog running acceleration time	0.1~3600s	0.1s	Defined by inverter model	○
F8.02	Jog running deceleration time	0.1~3600s	0.1s		○
F8.03	Acceleration time 2	0.1~3600s	0.1s		○
F8.04	Deceleration time 2	0.1~3600s	0.1s		○
F8.05	Acceleration time 3	0.1~3600s	0.1s		○
F8.06	Deceleration time 3	0.1~3600s	0.1s		○
F8.07	Acceleration time 4	0.1~3600s	0.1s		○
F8.08	Deceleration time 4	0.1~3600s	0.1s		○
F8.09	Skip frequency 1	0.00~F0.10	0.01Hz	0.00Hz	○
F8.10	Skip frequency 2	0.00~F0.10	0.01Hz	0.00Hz	○
F8.11	Skip frequency bandwidth	0.00~F0.10	0.01Hz	0.00Hz	○

Function Code	Function	Descriptions	Minimum Unit	Factory Setting	Modification Type
F8.12	FDT level	0.00~F0.10	0.01Hz	50.00Hz	○
F8.13	FDT lag	0.0~100.0%	0.1%	5.0%	○
F8.14	Detecting range of reached frequency	0.0~100.0% (Maxi. frequency)	0.1%	0.0%	○
F8.15	Braking threshold voltage	115.0~140.0% (standard DC bus voltage)	0.1%	120.0%	○
F8.16	Speed display coefficient	0.1~999.9%	0.1%	100.0%	○
8.17	Start/stop selection when running time is over	0:Keep running 1:Stop		0	○
F8.18	Running time setting	0~9999h	1h	9999	○
F8.19	Droop control	0.00Hz~10.00Hz	0.01Hz	0.00Hz	○
F8.20	Panel filter time selection	0.00~10.00s	0.01s	0.10s	○
F8.21	Output delay time selection	0~9999s	0.1s	0.0s	○
F8.22	Lower limit of frequency detecting	0.00~Maxi. frequency	0.01Hz	20.00Hz	○
F8.23	Upper limit of frequency detecting	0.00~Maxi. frequency	0.01Hz	40.00Hz	○
F8.24	Reserved				

Function Code	Function	Descriptions	Minimum Unit	Factory Setting	Modification Type
F8.25	Inverter rated power	0.4~700.0kW	0.1kW	Defined by inverter model	☉
F8.26	Inverter rated current	0.0~2000A	0.1A		☉
F8.27	Linear speed display coefficient	0.1~999.9% (linear speed= mechanical speed * F8.27)	0.1%	1.0%	○
F8.28 ~ F8.29	Reserved				
F9 Group: PID parameters					
F9.00	PID setting source	0:Keypad (F9.01) 1:Analog terminal AVI 2:Analog terminal ACI 3:Communication interface 4:Multi-function digital input terminals		0	○
F9.01	Keypad PID preset	0.0%~100.0%	0.1%	0.0%	●
F9.02	PID feedback source selection	0:Analog terminal AVI 1:Analog terminal ACI 2:AVI+ACI 3:Communication interface		0	○
F9.03	PID output characteristic	0: Positive 1: Negative		0	○
F9.04	Proportional gain (Kp)	0.00~100.0	0.01	0.10	○
F9.05	Integral time (Ti)	0.01~10.00s	0.01s	0.10s	○
F9.06	Differential time (Td)	0.00~10.00s	0.01s	0.00s	○

Function Code	Function	Descriptions	Minimum Unit	Factory Setting	Modification Type
F9.07	Sampling cycle (T)	0.01~100.0s	0.01s	0.10s	○
F9.08	Bias limit of PID control	0.0~100.0%	0.1%	0.0%	○
F9.09	Feedback lost detecting value	0.0~100.0%	0.1%	0.0%	○
F9.10	Feedback lost detecting time	0.0~3600.0s	0.1s	1.0s	○
F9.11	PID sleep function option	0: PID normal working 1: PID sleep		0	○
F9.12	PID sleep detecting delay time	0.0~3600.0s	0.1s	3.0s	○
F9.13	PID wake-up threshold	0.0~100.0%	0.1%	0.0%	○
F9.14	PID wake-up detecting delay time	0.0~3600.0s	0.1s	3.0s	○
F9.15	Lower frequency of PID sleep detecting	0.00Hz~20.00Hz	0.01Hz	10.00Hz	○
F9.16 ~ F9.18	Reserved				
FA Group: Protection and Malfunction Parameters					
FA.00	Motor overload protection	0:Disabled 1:Normal motor with low speed compensation 2:Variable frequency motor without low speed compensation		2	●

Function Code	Function	Descriptions	Minimum Unit	Factory Setting	Modification Type
FA.01	Motor over load protection	20.0%~120.0% (motor rated current)	0.1%	100.0%	○
FA.02	Threshold of trip-free	70.0%~110.0% (standard bus voltage)	0.1%	80.0%	○
FA.03	Decrease rate of trip-free	0.00Hz~F0.10	0.01Hz	0.00Hz	○
FA.04	Over-voltage stall protection	0:Disabled 1:Enabled		0	○
FA.05	Over-voltage stall protection point	110~150%	1%	120%	○
FA.06	Auto current limiting level	50~200%	1%	160%	○
FA.07	Frequency decrease rate when current limiting	0.00~50.00Hz/s	0.01Hz/s	10.00Hz/s	○
FA.08	Auto current limiting selection	0:Enabled 1: Disabled at constant speed		1	○
FA.09	Fault auto reset times	0~3		0	○
FA.10	Fault auto reset interval	0.1~100.0s	0.1s	1.0s	○
FA.11	Reserved				
FA.12	Phase-lack protection of input	0:Disabled 1:Enabled		1	○
FA.13	Phase-lack protection of output	0: Disabled 1:Enabled		1	○

Function Code	Function	Descriptions	Minimum Unit	Factory Setting	Modification Type
FA.14	Former twice faults type	0: No fault 1: Inverter module protection (E001) 2: Over-current when accelerate (E002) 3: Over-current when decelerate (E003) 4: Over-current at constant speed (E004) 5: Over-voltage when accelerate (E005) 6: Over-voltage when decelerate (E006)			⊙
FA.15	Former once fault type	7: Over-voltage at constant speed (E007) 8: Hardware overvoltage (E008) 9: Under voltage (E009) 10: Inverter overload (E010) 11: Motor overload (E011) 12: Phase-lack of input (E012) 13: Phase-lack of output (E013) 14: Heatsink overheating (E014) 15: External fault (E015) 16: Communication fault (E016) 17: Reserved			⊙
FA.16	Current fault type	18: Current detection fault (E018) 19: Motor autotuning fault (E019) 20: Reserved 21: Reserved 22: EEPROM fault (E022) 23: Pre-alarm fault when overload (E023) 24: PID feedback lost fault (E024) 25: Running time reached (E025) 26: Counting meter reached (FULL)			⊙
FA.17	Running frequency when fault occurs		Hz		⊙

Function Code	Function	Descriptions	Minimum Unit	Factory Setting	Modification Type
FA.18	Output current when fault occurs		A		⊙
FA.19	DC bus voltage when fault occurs		V	0.0V	⊙
FA.20	Input terminal status when fault occurs			0	⊙
FA.21	Output terminal status when fault occurs			0	⊙
FB Group: Swing Frequency and Counting Meter Parameters					
FB.00	Swing frequency bandwidth	0.0~100.0% (relative to setting frequency)	0.1%	0.0%	○
FB.01	Skip frequency bandwidth	0.0~50.0% (relative to swing frequency bandwidth)	0.1%	0.0%	○
FB.02	Rising time of swing frequency	0.1~3600.0s	0.1s	5.0s	○
FB.03	Dropping time of swing frequency	0.1~3600.0s	0.1s	5.0s	○
FB.04	Counting meter method	0:Start from zero when power on 1:Start from counting meter of the last time	0.1s	5.0s	○
FB.05	Roller perimeter of counting meter	0~9999cm	1cm	100cm	○
FB.06	Setting value of counting meter	0~9999m	1m	1000m	○

Function Code	Function	Descriptions	Minimum Unit	Factory Setting	Modification Type
FB.07	Clear up counting meter value	0:Invalid 1:Valid		0	○
FB.08	Counter value setting	FB.09~9999		0	○
FB.09	Designated counter value	0~FB.08		0	○
FB.10	Counting meter length	0:Actual counting length= displayed length* 1m 1: Actual counting length= displayed length* 10m		0	○
FC Group: RS485 Communication Parameters					
FC.00	Local address	1~247, 0 refers to the broadcast address		1	○
FC.01	Baud rate selection	0:1200BPS 1:2400BPS 2:4800BPS 3:9600BPS 4:19200BPS 5:38400BPS		3	○
FC.02	Data bit check	0: No check (N, 8, 1) for RTU 1: Even parity check (E, 8, 1) for RTU 2: Odd parity check (O, 8, 1) for RTU 3: No check (N, 8, 2) for RTU 4: Even parity check (E, 8, 2) for RTU 5: Odd parity check (O, 8, 2) for RTU		0	○
FC.03	Communication response delay time	0~200ms	1ms	5ms	○

Function Code	Function	Descriptions	Minimum Unit	Factory Setting	Modification Type
FC.04	Communication timeout fault time	0.0 (invalid), 0.1~100.0s	0.1s	0.0s	○
FC.05	Dispose of communication timeout fault	0:Alarm and coast to stop 1:No alarm and continue to run 2:No alarm but stop according to F1.05 (only when F0.01= 2) 3: No alarm but stop according to F1.05		1	○
FC.06	Transmission response action	Unit's digit: 0: Response to writing 1: No response to writing Ten's place: 0:Value not saved when power-off 1: Value saved when power-off		0	○
FD Group:Multi-step Speed and Simple PLC Parameters					
FD.00	Simple PLC operation method	0:Stop after operation once time 1:Keep the final value after operation once time 2:Operation in cycles		0	○
FD.01	Memory option of simple PLC when power-off	0: Invalid 1:Valid		0	○
FD.02	Multi- step speed 0	-100~100%	0.1%	0.0%	○
FD.03	0 th step running time	0.0~6553s(m)	0.1s(m)	0.0s	○
FD.04	Multi- step speed 1	-100~100%	0.1%	0.0%	○
FD.05	1 st step running time	0.0~6553s(m)	0.1s(m)	0.0s	○

Function Code	Function	Descriptions	Minimum Unit	Factory Setting	Modification Type
FD.06	Multi- step speed 2	-100~100%	0.1%	0.0%	○
FD.07	2 nd step running time	0.0~6553s(m)	0.1s(m)	0.0s	○
FD.08	Multi- step speed 3	-100~100%	0.1%	0.0%	○
FD.09	3 rd step running time	0.0~6553s(m)	0.1s(m)	0.0s	○
FD.10	Multi- step speed 4	-100~100%	0.1%	0.0%	○
FD.11	4 th step running time	0.0~6553s(m)	0.1s(m)	0.0s	○
FD.12	Multi- step speed 5	-100~100%	0.1%	0.0%	○
FD.13	5 th step running time	0.0~6553s(m)	0.1s(m)	0.0s	○
FD.14	Multi- step speed 6	-100~100%	0.1%	0.0%	○
FD.15	6 th step running time	0.0~6553s(m)	0.1s(m)	0.0s	○
FD.16	Multi- step speed 7	-100~100%	0.1%	0.0%	○
FD.17	7 th step running time	0.0~6553s(m)	0.1s(m)	0.0s	○
FD.18	Multi- step speed 8	-100~100%	0.1%	0.0%	○
FD.19	8 th step running time	0.0~6553s(m)	0.1s(m)	0.0s	○

Function Code	Function	Descriptions	Minimum Unit	Factory Setting	Modification Type
FD.20	Multi- step speed 9	-100~100%	0.1%	0.0%	○
FD.21	9 th step running time	0.0~6553s(m)	0.1s(m)	0.0s	○
FD.22	Multi- step speed 10	-100~100%	0.1%	0.0%	○
FD.23	10 th step running time	0.0~6553s(m)	0.1s(m)	0.0s	○
FD.24	Multi- step speed 11	-100~100%	0.1%	0.0%	○
FD.25	11 th step running time	0.0~6553s(m)	0.1s(m)	0.0s	○
FD.26	Multi- step speed 12	-100~100%	0.1%	0.0%	○
FD.27	12 th step running time	0.0~6553s(m)	0.1s(m)	0.0s	○
FD.28	Multi- step speed 13	-100~100%	0.1%	0.0%	○
FD.29	13 th step running time	0.0~6553s(m)	0.1s(m)	0.0s	○
FD.30	Multi- step speed 14	-100~100%	0.1%	0.0%	○
FD.31	14 th step running time	0.0~6553s(m)	0.1s(m)	0.0s	○
FD.32	Multi- step speed 15	-100~100%	0.1%	0.0%	○
FD.33	15 th step running time	0.0~6553s(m)	0.1s(m)	0.0s	○

Function Code	Function	Descriptions	Minimum Unit	Factory Setting	Modification Type
FD.34	Acceleration time of 0 th ~7 th steps	0~0xFFFF		0	○
FD.35	Acceleration time of 8 th ~15 th steps	0~0xFFFF		0	○
FD.36	PLC restart method	0: Restart from 1 st step 1: Restart from break-off frequency	0	0	○
FD.37	PLC operation time unit	0: second (s) 1: minute (m)		0	○
FE Group: Reserved					
FF Group: Reserved Factory Parameters					

Chapter 6 Trouble Shooting

6.1 Fault and Trouble Shooting

Fault Code	Fault Type	Reason	Solution
E001	IGBT module fault	1: Acceleration time is too short 2: IGBT module damaged 3: Malfunction caused by interference 4: Grounding is not properly	1: Increase acceleration time 2: Ask for support 3: Inspect external equipment and eliminate interference 4: Check grounding wire
E002	Over-current when acceleration	1: Accelerate too fast 2: Input voltage is too low 3: Inverter capacity is too low	1: Increase acceleration time 2: Inspect the input power supply or wiring 3: Select larger capacity inverter
E003	Over-current when deceleration	1: Decelerate too fast 2: Load is too heavy and has large inertia 3: Inverter capacity is too low	1: Increase deceleration time 2: Add suitable braking units 3: Select larger capacity inverter
E004	Over-current at constant running speed	1: Sudden change of load 2: Input voltage is too low 3: Inverter capacity is too low	1: Check the load 2: Inspect the input power supply or wiring 3: Select larger capacity inverter
E005	Over-voltage when acceleration	1: Input voltage abnormal 2: Restart the motor when instantaneous trip-off occurs	1: Inspect input power 2: Avoid prompt restart when trip-off
E006	Over-voltage when deceleration	1: Decelerate too fast 2: Load is too heavy and has large inertia 3: Input voltage abnormal	1: Increase deceleration time 2: Add suitable braking units 3: Inspect input power

Fault Code	Fault Type	Reason	Solution
E007	Over-voltage at constant running speed	1: Input voltage abnormal 2: Load inertia is too large	1: Install input AC reactor 2: Add suitable braking units
E008	Hardware over-voltage	1: Input voltage abnormal 2: Decelerate too fast 3: Load inertia is too large	1: Inspect the input power supply or wiring 2: Increase deceleration time 3: Add suitable braking units
E009	Under voltage of DC bus	Input voltage is too low	Inspect power grid
E010	Inverter overload	1: Accelerate too fast 2: Restart the motor when instantaneous trip-off occurs 3: Input voltage is too low 4: Load is too heavy	1: Increase acceleration time 2: Avoid prompt restart when trip-off 3: Inspect power grid 4: Select larger capacity inverter
E011	Motor overload	1: Input voltage is too low 2: Improper setting of motor rated current 3: Improper motor's overload protection threshold 4: Inverter capacity is too low	1: Inspect voltage of power grid 2: Properly setting of motor rated current 3: Inspect load and boost the torque 4: Select larger capacity inverter
E012	Phase-lack of input side	Phase-lack of R, S, T	Inspect the input power supply or wiring
E013	Phase-lack of output side	1: There is a broken wire in the output cable 2: There is a broken wire in the motor winding. 3.: Output terminals are loose	Check the wiring and installation

Fault Code	Fault Type	Reason	Solution
E014	Inverter overheat	1: Instantaneous over current of inverter 2: Output short circuit 3: Cooling fans of inverter stop or damaged. Obstruction of ventilation channel 4: Ambient temperature is too high 5: The cables or terminals are loose 6: Power circuit abnormal 7: Control PCB board abnormal	1: Refer to over current solutions 2: Use the good wire 3: Replace cooling fan and clear the ventilation channel 4: Decrease the ambient temperature 5: Inspect and tighten the wire and terminals 6 and 7: Ask for support
E015	External fault	External fault input terminals take effect	Inspect external equipment
E016	Communication fault	1: Improper baud rate setting 2: Receive wrong data 3: Communication is interrupted for long time	1: Set proper baud rate 2: Push STOP/RESET to reset and ask for support 3: Check communication devices and cables
E017	Reserved		
E018	Current detection fault	1: Wires or connectors of control board are loose 2: Amplifying circuit abnormal 3: Hall sensor is damaged 4: Power circuit abnormal	1: Check the wiring and connectors 2,3 and 4: Ask for support
E019	Autotuning fault	1: Improper setting of motor rated parameters 2: Overtime of autotuning 3: Too much error	1: Set rated parameters according to motor nameplate 2: Check motor's wiring 3: Make motor uncoupled with load and autotune again
E020	Reserved		

Fault Code	Fault Type	Reason	Solution
E021	Reserved		
E022	EEPROM fault	1: Read/ Write fault of control parameters 2: EEPROM damaged	Push STOP/RESET to reset and ask for support
E023	Overload pre-alarm	1: Accelerate too fast 2: Restart the motor when instantaneous trip-off occurs 3: Input voltage is too low 4: Load is too heavy	1: Increase acceleration time 2: Avoid prompt restart when trip-off 3: Inspect power grid 4: Select larger capacity inverter 5: Set the suitable parameter of F3.10
E024	PID feedback lost fault	1: Sensor disconnect or loose contact 2: Detecting time of disconnection is too short 3: No feedback signal of system	1: Check sensor installation and connection 2: Extend the detecting time of sensor disconnection
FULL	Counting meter full	1: Setting value of counting meter reached 2: The value of counting meter gets to 9999m	Push STOP/RESET key to reset

6.2 Common Faults and Solutions

Inverter may have following faults or malfunctions during operation, please refer to the following solutions.

No display after power on:

- Inspect whether the voltage of power supply is the same as the inverter rated voltage or not with multi-meter. If the power supply has problem, inspect and solve it.
- Inspect whether the three-phase rectify bridge is in good condition or not. If the rectification bridge is burst out, ask for support.

Power supply air switch trips off when power on:

- Inspect whether the input power supply is grounded or short circuit. Solve this problem.
- Inspect whether the rectify bridge has been burnt or not. If it is damaged, ask for support.

Motor doesn't run after inverter works:

- Inspect if there is balanced three-phase output among U, V, W. If yes, then motor could be damaged, or mechanically locked.
- If the output is unbalanced or lost, the inverter drive board or the output module may be damaged, ask for support..

Inverter displays normally when power on, but switch at the input side trips when running:

- Inspect whether the output side of inverter is short circuit. If yes, ask for support.
- Inspect whether ground fault exists. If yes, solve it.
- If trip happens occasionally and the distance between motor and inverter is too far, it is recommended to install output AC reactor.
- Inspect whether the output module is burnt or not. If yes, ask for support.

Chapter 7 Data Address Table of Function Code

F0.00	0
F0.01	1
F0.02	2
F0.03	3
F0.04	4
F0.05	5
F0.06	6
F0.07	7
F0.08	8
F0.09	9
F0.10	10
F0.11	11
F0.12	12
F0.13	13
F0.14	14
F0.15	15
F0.16	16
F0.17	17
F0.18	18
F0.19	19
F0.20	20
F0.21	21
F0.22	22
F0.23	23
F0.24	24
F0.25	25
F1.00	26
F1.01	27
F1.02	28
F1.03	29
F1.04	30
F1.05	31
F1.06	32

F1.07	33
F1.08	34
F1.09	35
F1.10	36
F1.11	37
F1.12	38
F1.13	39
F1.14	40
F1.15	41
F1.16	42
F1.17	43
F1.18	44
F1.19	45
F1.20	46
F1.21	47
F2.00	48
F2.01	49
F2.02	50
F2.03	51
F2.04	52
F2.05	53
F2.06	54
F2.07	55
F2.08	56
F2.09	57
F2.10	58
F2.11	59
F2.12	60
F3.00	61
F3.01	62
F3.02	63
F3.03	64
F3.04	68

F3.05	66
F3.06	67
F3.07	68
F3.08	69
F3.09	70
F3.10	71
F3.11	72
F3.12	73
F4.00	74
F4.01	75
F4.02	76
F4.03	77
F4.04	78
F4.05	79
F4.06	80
F4.07	81
F4.08	82
F4.09	83
F4.10	84
F4.11	85
F4.12	86
F4.13	87
F4.14	88
F4.15	89
F4.16	90
F4.17	91
F5.00	92
F5.01	93
F5.02	94
F5.03	95
F5.04	96
F5.05	97
F5.06	98

F5. 07	99
F5. 08	100
F5. 09	101
F5. 10	102
F5. 11	103
F5. 12	104
F5. 13	105
F5. 14	106
F5. 15	107
F5. 16	108
F5. 17	109
F5. 18	110
F5. 19	111
F5. 20	112
F5. 21	113
F5. 22	114
F5. 23	115
F5. 24	116
F5. 25	117
F5. 26	118
F5. 27	119
F5. 28	120
F5. 29	121
F5. 30	122
F5. 31	123
F5. 32	124
F6. 00	125
F6. 01	126
F6. 02	127
F6. 03	128
F6. 04	129
F6. 05	130
F6. 06	131
F6. 07	132
F6. 08	133
F6. 09	134

F6. 10	135
F6. 11	136
F6. 12	137
F6. 13	138
F6. 14	139
F6. 15	140
F6. 16	141
F6. 17	142
F6. 18	143
F7. 00	144
F7. 01	145
F7. 02	146
F7. 03	147
F7. 04	148
F7. 05	149
F7. 06	150
F7. 07	151
F7. 08	152
F7. 09	153
F7. 10	154
F7. 11	155
F7. 12	156
F7. 13	157
F8. 00	158
F8. 01	159
F8. 02	160
F8. 03	161
F8. 04	162
F8. 05	163
F8. 06	164
F8. 07	165
F8. 08	166
F8. 09	167
F8. 10	168
F8. 11	169
F8. 12	170

F8. 13	171
F8. 14	172
F8. 15	173
F8. 16	174
F8. 17	175
F8. 18	176
F8. 19	177
F8. 20	178
F8. 21	179
F8. 22	180
F8. 23	181
F8. 24	182
F8. 25	183
F8. 26	184
F8. 27	185
F8. 28	186
F8. 29	187
F9. 00	188
F9. 01	189
F9. 02	190
F9. 03	191
F9. 04	192
F9. 05	193
F9. 06	194
F9. 07	195
F9. 08	196
F9. 09	197
F9. 10	198
F9. 11	199
F9. 12	200
F9. 13	201
F9. 14	202
F9. 15	203
F9. 16	204
F9. 17	205
F9. 18	206

FA. 00	207
FA. 01	208
FA. 02	209
FA. 03	210
FA. 04	211
FA. 05	212
FA. 06	213
FA. 07	214
FA. 08	215
FA. 09	216
FA. 10	217
FA. 11	218
FA. 12	219
FA. 13	220
FA. 14	221
FA. 15	222
FA. 16	223
FA. 17	224
FA. 18	225
FA. 19	226
FA. 20	227
FA. 21	228
FB. 00	229
FB. 01	230
FB. 02	231
FB. 03	232
FB. 04	233
FB. 05	234
FB. 06	235
FB. 07	236
FB. 08	237
FB. 09	238
FB. 10	239
FC. 00	240
FC. 01	241
FC. 02	242

FC. 03	243
FC. 04	244
FC. 05	245
FC. 06	246
FD. 00	247
FD. 01	248
FD. 02	249
FD. 03	250
FD. 04	251
FD. 05	252
FD. 06	253
FD. 07	254
FD. 08	255
FD. 09	256
FD. 10	257
FD. 11	258
FD. 12	259
FD. 13	260
FD. 14	261
FD. 15	262
FD. 16	263
FD. 17	264
FD. 18	265
FD. 19	266
FD. 20	267
FD. 21	268
FD. 22	269
FD. 23	270
FD. 24	271
FD. 25	272
FD. 26	273
FD. 27	274
FD. 28	275
FD. 29	276
FD. 30	277
FD. 31	278

FD. 32	279
FD. 33	280
FD. 34	281
FD. 35	282
FD. 36	283
FD. 37	284

Guangzhou Sanjing Electric CO., LTD.

TEL: (00)86-20-6660 8588 6660 8519 FAX: (00)86-20-6660 8589

ADD: SAJ Innovation Park, No.9, Lizhishan Road, Science City,
Guangzhou High-tech Zone, Guangdong, P.R.China

V1.0

Inverter